

GENERAL PANEL INFORMATION

FRP - FIBERGLASS REINFORCED PLASTIC PANELS (Super600 or WeatherGlaze) are translucent laminates consisting of a uniform mat of high-strength glass fibers imbedded in organic resin. The resin matrix cures under heat to a solid material which is lightweight, strong, and shatter-resistant; with excellent light diffusion characteristics. Colors are compounded into the resin before cure, thus making the colors an integral part of the composite material.

FRP panels are durable, rot-proof, waterproof, and not harmed by ordinary cleaning solutions. Sequentia Corrugated panels that are reinforced with glass fibers (frp, fiberglass reinforced panels) that will expand and contract up to three times less than PVC and polycarbonate panels, which provides for a more stable product in both hot and cold conditions. Panels install much like corrugated metal and provide the added benefit of light transmission.

POLYCARBONATE PANELS (POLY 300) contain a translucent UV resistant film on only one side of each panel. Each polycarbonate panel is imprinted with the following: "THIS SIDE OUT". The side of the panel with this information should be installed toward the sun or exterior of the structure it is being used on. The other side of the panel has little UV resistance and will be damaged by the harmful rays of the sun. *Polycarbonate panels are not recommended as exterior privacy walls (which are installed vertically vs. horizontally) because both sides of the panel can receive direct exposure to the sun, hence damaging the panel.*

PVC PANELS (WeatherTuf) are an economical option that performs well in mild climate areas. They are made of a flexible material that is lightweight and resists corrosion, cracking and splitting.

STORE PANELS PROPERLY: While a single panel easily withstands exposure to sunlight and the elements, a stack of fiberglass panels will trap heat and moisture, causing clouding to the panels. To avoid this irreversible effect, panels should be stored in a dry, shaded, well-ventilated area. Store panels on edge or on end to shed water. Skids should be elevated at one end with wood spacers.

FRAMING: Provide purlin for water drainage rafter member at recommended maximum intervals required for corrugation selected. See LOAD/SPAN CHART on first column. **CUTTING:** Cut fiberglass, PVC, and Polycarbonate panels using hand or power saws. Saw blade should be fine-toothed carbide tipped, or safety fabric reinforced abrasive disc. Face shields and appropriate safety equipment should be worn. **DRILLING:** All panels should be pre-drilled not less than 1-1/2" from panel ends and holes drilled a minimum of 1/16" larger for fiberglass panels, and 1/8" larger for PVC and Polycarbonate panels than the fastener diameter. Panels may be drilled individually or several at a time.

CLEANING INSTRUCTIONS: Panels may be washed with either mild detergent-type cleaners or by steam and high-pressure spray systems. Apply cleaners with sponge or soft brush and rinse thoroughly in cold water to eliminate cleaning agent film build-up. Always follow cleaning agent manufacturer's instructions. Test small area before applying over entire surface. Hard water deposits may be removed with a 10% solution of acetic acid in COLD water. Rinse thoroughly. Panels may be waxed to maintain luster and beauty. Always follow wax manufacturer's application instructions.

MINIMUM BEND RADIUS: (2.67" x 9/16") Flexing the panel to the point of buckling can cause fracture and rapid deterioration at the fracture point. Install at ambient temperatures not below 60°F.

MAXIMUM RECOMMENDED SPANS: The following data is based upon uniform loading of corrugated FRP panels with a safety factor of 2.5, and fastened as recommended. In heavy snow areas, Super600 panels are recommended and closer spacing of purlins should be considered. While panels may not fail under heavy snow loads, strain at fastening points can cause slight cracking.

CORRUGATED PROFILE	SERIES	MAXIMUM RECOMMENDED ROOF SPANS			
		10 psf	20 psf	30 psf	40 psf
2.67" x 9/16"	C255 - Super600	38"	32"	30"	24"
	C25T - Weatherglaze	38"	31"	27"	24"
	PVC - WeatherTuf	30"	24"	20"	18"

*C255 - Super600
C25T - Weatherglaze
PVC - WeatherTuf

NOTES:

- Table is based on section properties or actual load tests (available upon request).
- Design loads are governed by local building codes. Consult code authorities for specific loads and stresses.
- Information is provided as preliminary data for designers. It should be checked and verified for use with a duly-licensed engineer or architect.

Sequentia is a registered trademark of Crane Composites, Inc.
1.800.435.0080 • 815.467.8600 • Fax: 815.467.8666
www.sequentiacorrugated.com
Form 2741 rev.1 (3492) 08/07

SEQUENTIA PANEL INSTALLATION

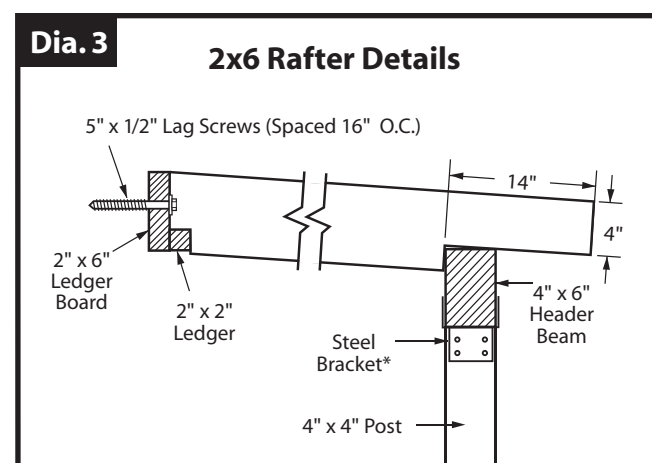

* Follow manufacturer's instructions for installing

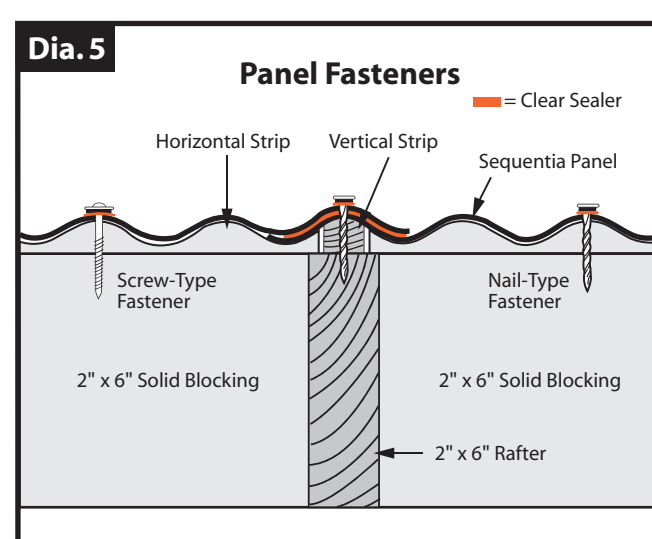
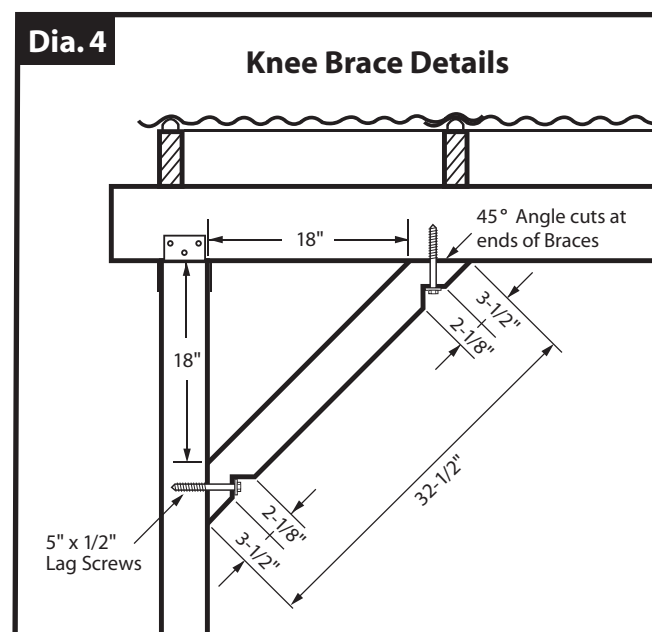

These instructions are intended as guidelines for proper installation procedures. In the use of tools, fasteners, sealants, and adhesives, follow manufacturer's recommended procedures.

INSTALLING: For best protection against prevailing winds and weather, install panels beginning at leeward end of run and work to windward.

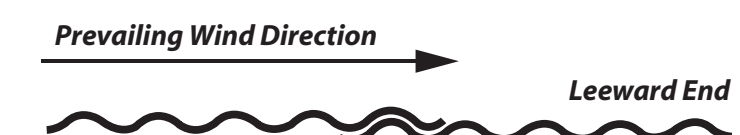

- Provide a minimum of one corrugation overlap at sides.
- Provide 8" end-laps for roofs with pitch of less than 4/12. Use 6" end-laps for pitches greater than 4/12.
- Fasten panels through crowns at every second corrugation. Fasteners with armored Neoprene washers are recommended. Space fasteners 6" to 8" on-center along panel edges and 12" to 16" on-center for intermediate rafters and blocking.

CONSTRUCTION NOTES:

- To avoid deflection of panels, tighten screws until washers will not rotate, then tighten one more turn.
- Avoid excess burrs on drilled or punched holes to protect Neoprene sealing face.
- To help insure weathertight roof, apply a small amount of clear sealer at each hole before installing nails or screws.

RECOMMENDED OVERLAP:

(2.67" x 9/16") Overlaps shown will provide best protection against leakage and air infiltration. Vinyl lap seal and/or mastic must also be used to achieve effective seal on side-laps and end-laps.

TYPICAL FASTENERS include aluminum or galvanized nails or wood screws with Neoprene washers. Fastener selection is dependent upon type of corrugation and understructure material used. Panels should be pre-drilled a minimum of 1/16" larger than fastener diameter.

* #10 x 2" Galvanized "polebarn" screw with 1/2" armored Neoprene washer.

* 1-3/4" x .145" Alum. helix nail (screw nail) with Neoprene washer.

UNDER NO CIRCUMSTANCES should panels be allowed to support undistributed loads such as the weight of a human body. Use only approved roof ladders and planking.

ELEVATIONS

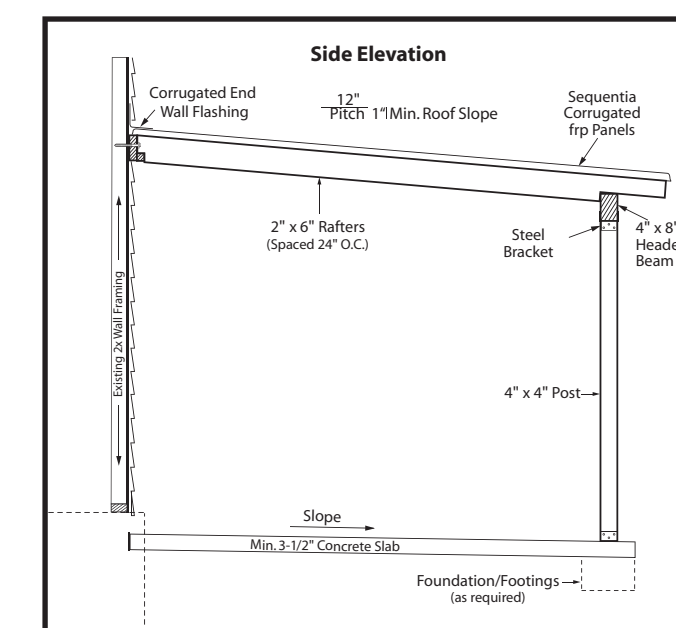
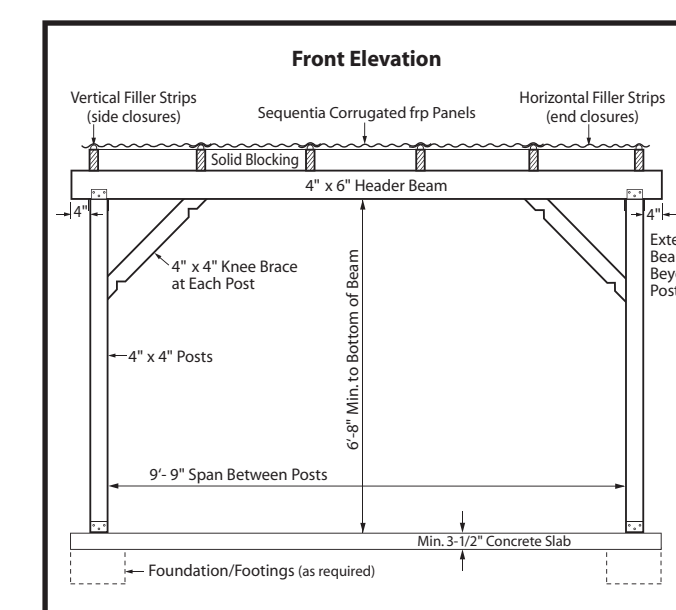

PATIO COVER PLANS

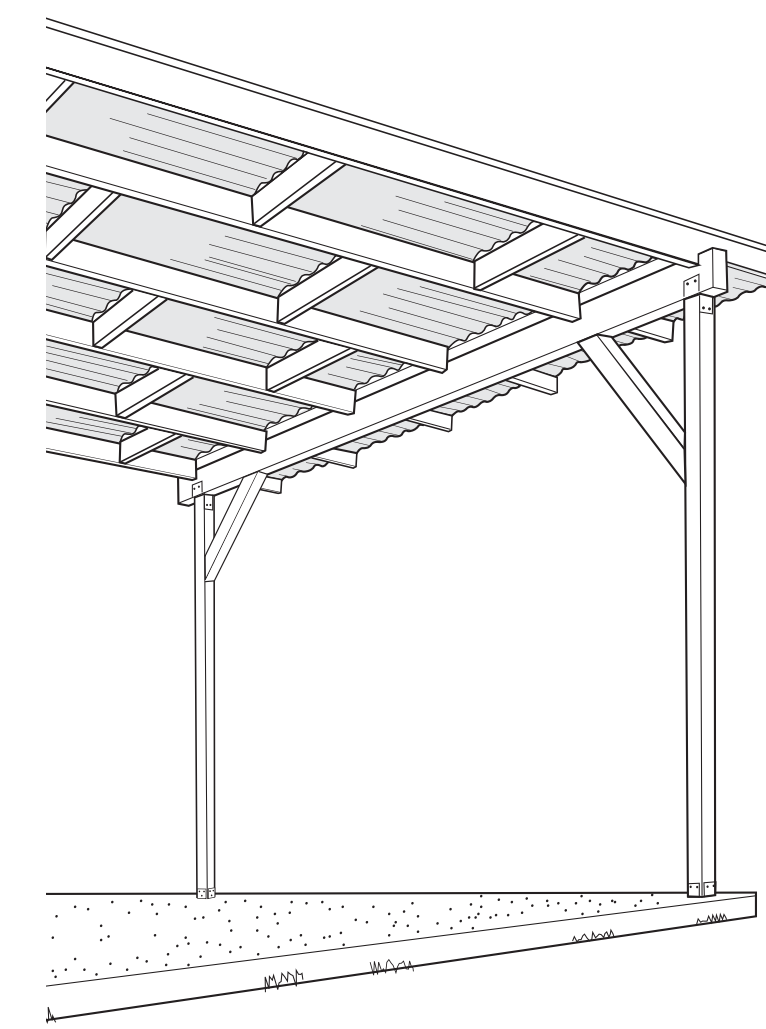

sequentia
CORRUGATED

www.sequentiacorrugated.com

sequentia
CORRUGATED

For answers to your questions and complete product specifications, visit www.sequentiacorrugated.com

BUILDING SAFETY

PLEASE READ ALL INSTRUCTIONS BEFORE BEGINNING INSTALLATION.

These guidelines are provided in good faith to help prevent installation problems caused by common errors. Crane Composites, Inc. bears no responsibility for installation actions taken or not taken. There are many nuances of installation that Crane Composites, Inc. assumes are general construction knowledge to an experienced installer; such nuances are not included in these instructions. Rather, these installation guidelines are strictly recommendations, not intended to serve as a step-by-step, foolproof installation checklist. Selection of an experienced frp installer is the sole responsibility of the project owner and architect.

If you have any questions about installation techniques for your particular project, please call:

800.435.0080 or 815.467.8600
Ask for an Inside Sales Representative.

IMPORTANT: Before beginning this project, be sure to check your local building codes pertaining to locating and constructing patio covers; obtain any permits and inspections that may be required.

WARNING: As required by law, before you dig on the construction site, have all buried utilities (electric, gas, water, phone, cable, etc.) located and clearly marked by a qualified professional.

Corrugated Fiberglass Panels install easily with ordinary tools and may be drilled, sawed, punched, or nailed without damage.

WHEN CUTTING OR DRILLING FRP PANELS, ALWAYS WEAR PROTECTIVE GLASSES OR GOGGLES AND A MASK WHICH COVERS THE FACE AND MOUTH.

Skin irritation due to glass fibers may be avoided by applying a barrier cream to exposed skin areas prior to working with corrugated panels.

DO NOT WALK ON PANELS. Observe simple fire precautions. Similar to wood of equal thickness, fiberglass panels can be flash-ignited at approximately 650°F.

MATERIAL LIST

Lumber for 10' x 10' Patio Cover:

- (2) 8' L 4" x 4" corner posts
- (1) 6' L 4" x 4" knee braces
- (1) 12' L 4" x 6" header beam
- (1) 10' L 2" x 6" ledger board
- (1) 10' L 2" x 2" ledger
- (6) 10' L 2" x 6" rafters
- (5) 8' L 2" x 6" solid blocking

Hardware:

- (2) Steel Brackets posts to concrete*
- (2) Steel Brackets beam to posts
- (7) 5" x 1/2" Hex Lag Screws ledger board
- (7) 5" x 1/2" Hex Lag Screws knee braces
- (14) 1-1/4" Flat Washers use with lag bolts
- 1lb 1" Galvanized Nails horizontal strips
- 1lb 1-1/2" Galv. 4d Nails vertical strips
- 5lbs 3-1/2" Galv. 16d Nails 2x framing
- 5lbs 1-3/4" Alum. Helix Nails (Screw Nails) roof panels
- Or:
- 8lbs 2" Galv. Polebarn Screws roof panels
- (4) 36" Alum. Corrugated End Wall Flashing
- (5) 10 oz. Cartridges clear panel sealer

Sequentia Corrugated Products:

- (5) 26" W x 10' L Corrugated Roof Panels
- (7) 8' Length vertical filler strips
- (5) 8' Length horizontal filler strips

Note: For larger or smaller patio cover plans, add or subtract materials accordingly.

* Depending upon the bracket style selected, additional fasteners may be required. Follow manufacturer's instructions.

The use of corrosion resistant hardware is strongly recommended for all areas.

Recommended Tools:

- Hammer
- Carpenter Square
- 4" Level
- Power Circular Saw
- Power Drill and Bits: 1/8" and 3/8"
- Ratchet Wrench with 3/4" Socket
- Caulking Gun
- Screw Gun with #2 Phillip-head Bit
- Needed only if framing is assembled with screws or roof panels are fastened with screws

FRAMING ASSEMBLY PROCEDURE

- Install concrete slab and footings in accordance with local building code requirements.
Note: Building code requirements and available hardware styles will vary depending on where you live and the size of your plan. Make necessary adjustments accordingly. Follow manufacturer's instructions for installing anchor brackets.
- Assemble ledger board and fasten to existing structure using 5" x 1/2" hex head lag screws. Note: Remove siding from behind ledger board before installing. See Diagram 4.
- Fasten 4" x 4" posts to concrete slab/footings using approved steel anchor brackets. Use a 4' level and temporary wood bracing to hold posts in an upright level position. (Dia.1)
- Important:** Have someone help lift and hold beam for this step. With 4" x 4" posts braced securely, fasten the 4" x 6" beam header to top of posts, using approved steel mounting brackets. See Diagram 3.
- Install permanent knee braces from posts to beam, as building code requires. Remove temporary bracing. See Diagram 4.
- Cut and install rafters according to Diagrams 3. Option: approved rafter hangers may be used (if not required) in conjunction with ledger board. **Rafters must install parallel.**
- For ease of assembly, install 2" x 6" solid blocking as suggested in Diagram 2. Option: blocking can be staggered differently and/or reduced to 2" x 4"s to suit personal taste.
- Nail vertical edge strips to tops of rafters, using 1-1/2" galvanized nails. Hint: drill pilot holes to prevent splitting.
- Determine necessary cuts for horizontal cross strips. Note: Cut crown profiles to match-up with vertical edge strips. (See Diagram 5.) Important: Test-fit the first cut strip, using a short piece of corrugated panel. When satisfied, use test piece as a pattern for marking and cutting remaining horizontal pieces. Cut strips 1/4" shorter than needed to allow shifting. Tack horizontal strips to tops of blocking boards using 1" nails in recesses between crowns. Continue checking alignment of strips, using a small strip of corrugated panel.
- For easier, neater finishing, paint or stain patio cover framing before installing corrugated panels onto roof.
- Follow corrugated panel installation instructions for fastening panels to roof framing.
- Install corrugated end wall flashing: Place flashing behind existing siding where possible. Use approved mastic to bond flashing to masonry walls. **WARNING:** Do not step or kneel on corrugated panels without using planks to distribute weight.

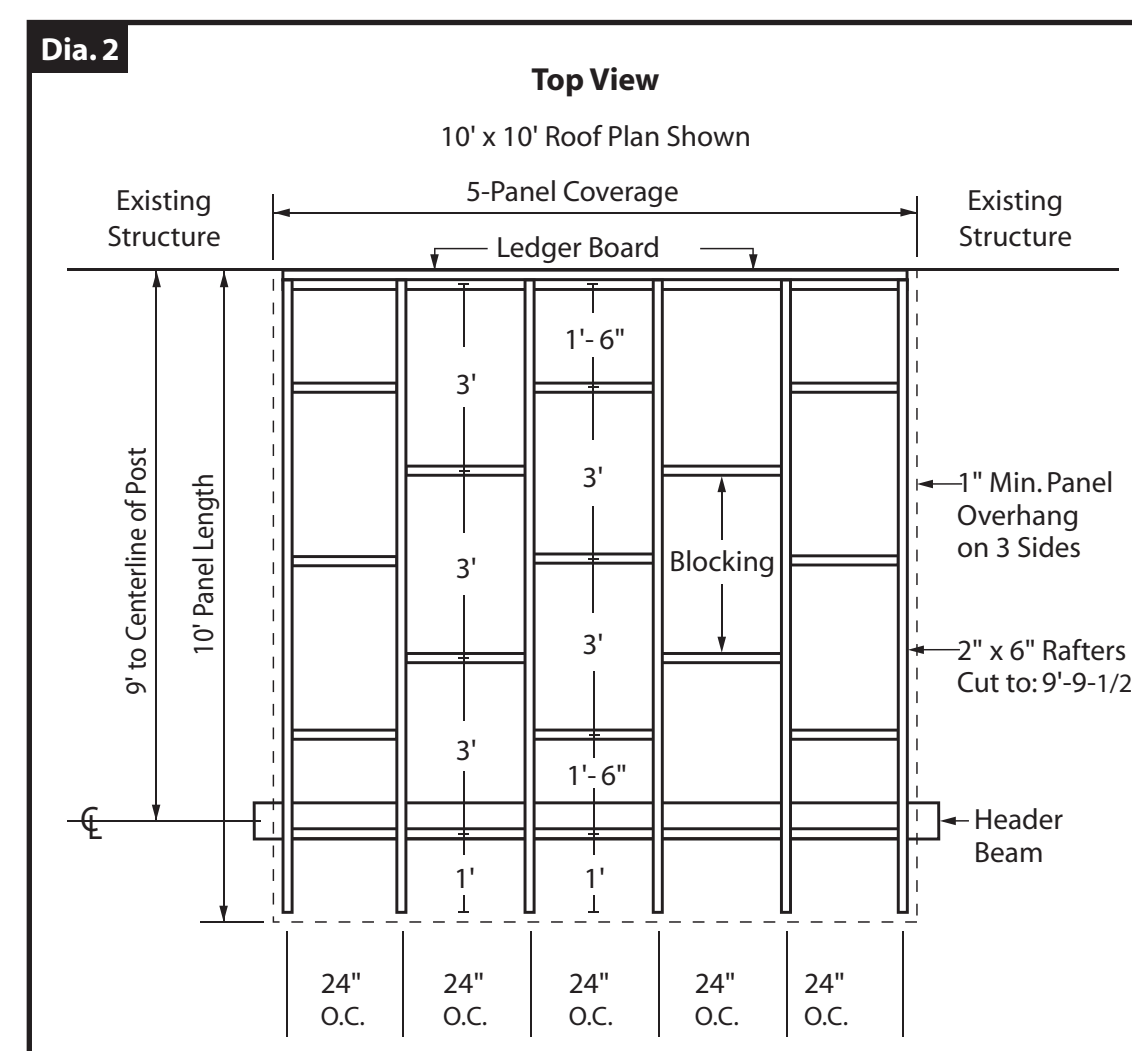
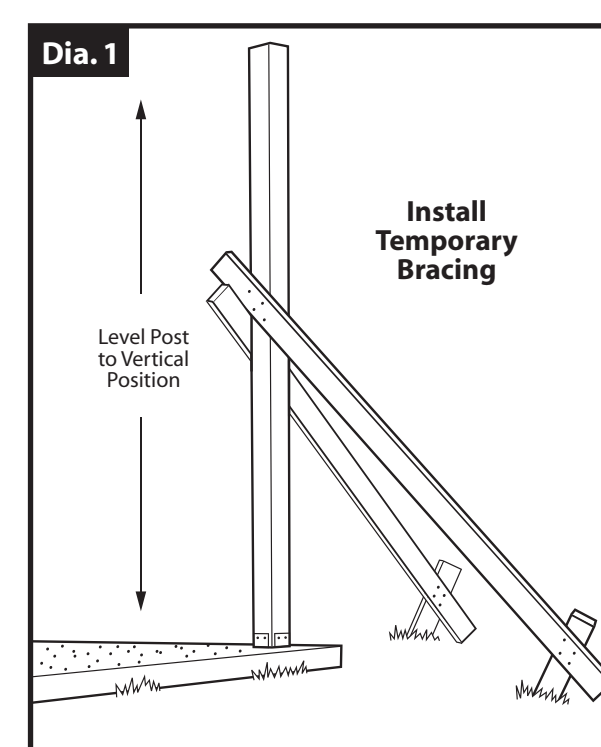

PATIO COVER INSTRUCTIONS

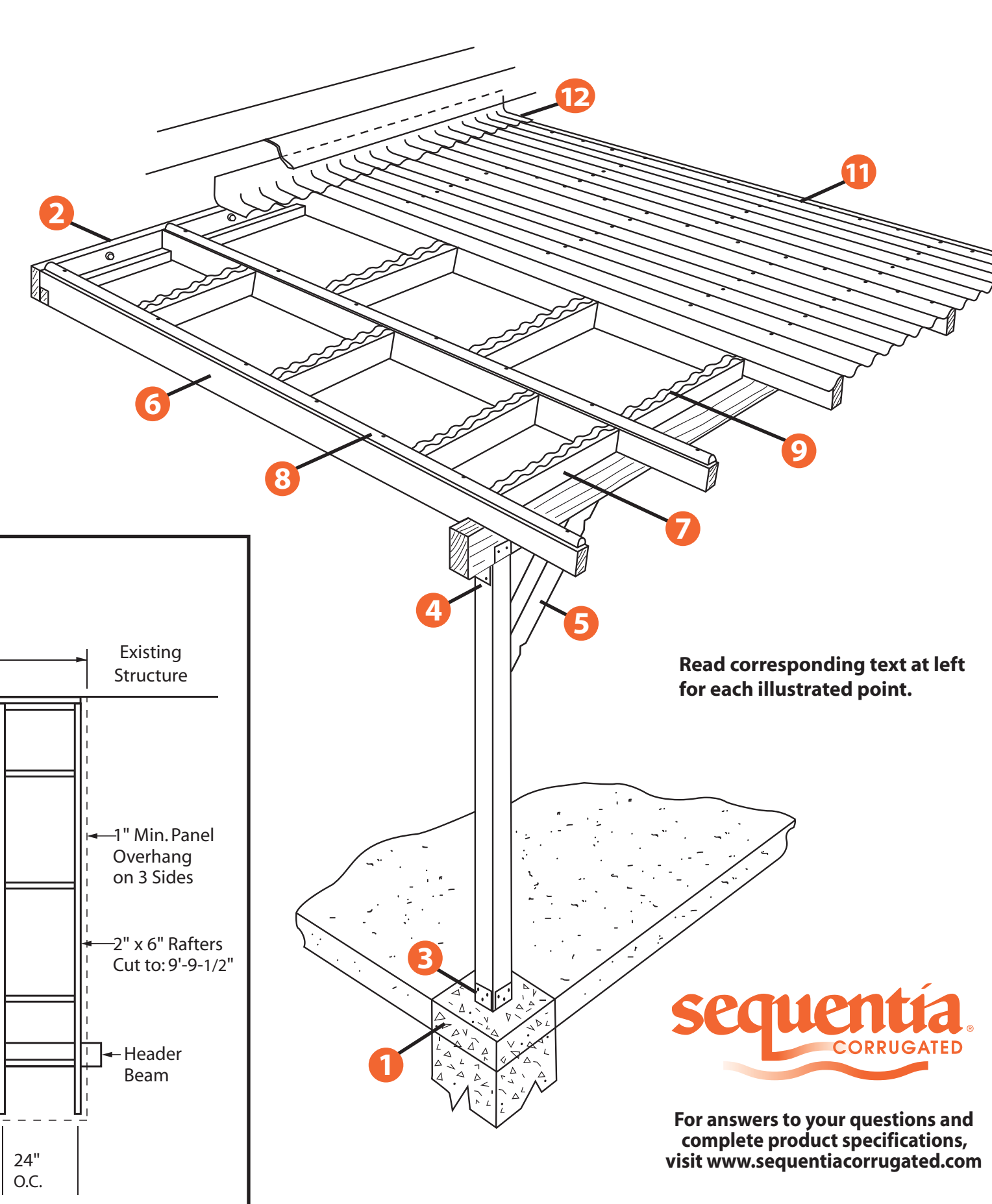

Read corresponding text at left for each illustrated point.

sequentia
CORRUGATED

For answers to your questions and complete product specifications, visit www.sequentiacorrugated.com